

CAD FILE:

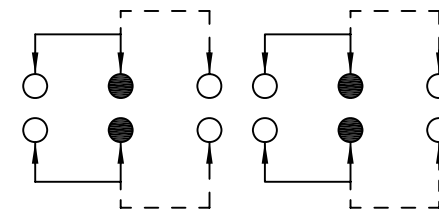

SCHEMATIC (NON-SHORTING)

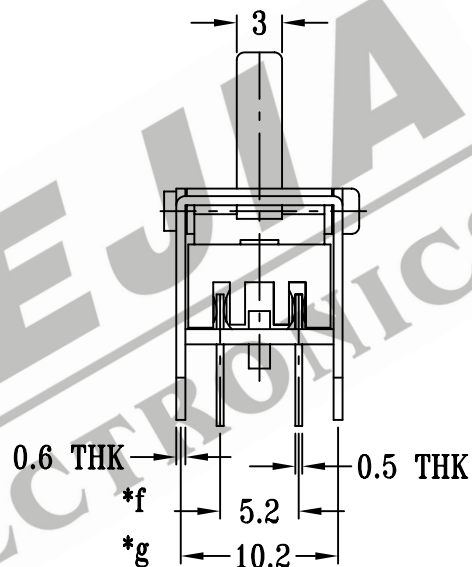
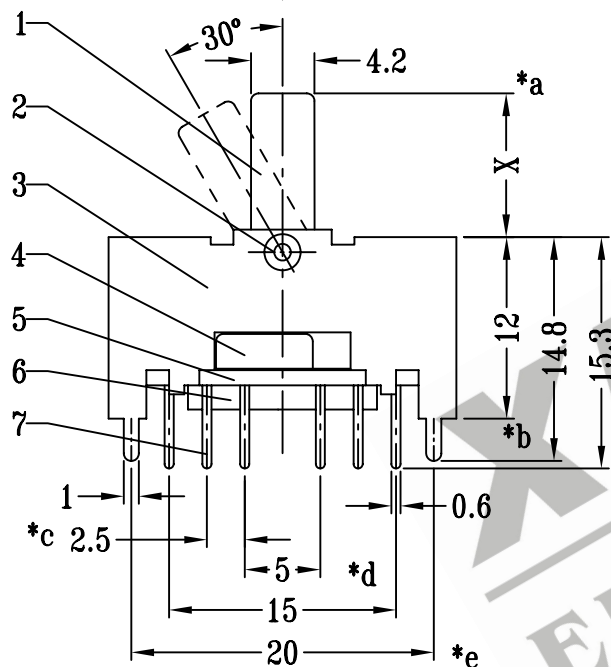
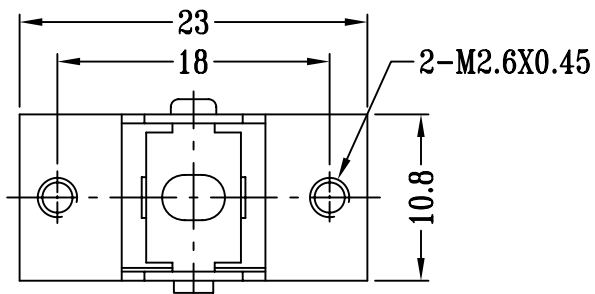
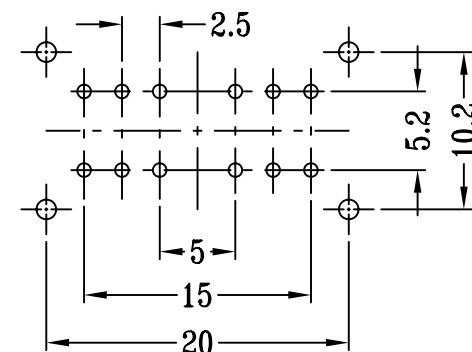

P.C.B LAYOUT

10	CONTACT (CLIP)	PBS	4	Ag CLAD
9	PRESS BAR	POM	1	WHITE
8	SPRING	STEEL WIRE	1	TEMPER
7	TERMINAL	BRASS STRIP	12	Ag PLATED OVER Ni PLATED
6	POSITION PLATE	POM	1	BLACK
5	BASE	PHENOLIC RESIN	1	NATURAL
4	SLIDER	POM	1	BLACK
3	FRAME	STEEL STRIP	1	Ni PLATED
2	RIVET	COPPER	1	Ni PLATED
1	NOB	PC	1	BLACK
NO.	PARTS	MATERIALS	Q'TY	FINISH

注:带"*"表示关键尺寸(7个)

TOLERANCE UNLESS SPECIFIED		SHENZHEN XIEJIA ELECTRONICS CO.,LTD.		
WITHIN: 1.5±0.1mm OVER: 1.5±0.2mm		ISSUE	DATE	DESCRIPTIONS OF REVISION
TITLE: TOGGLE SWITCH		UNIT: mm	DRWG NO.: XJ-DR-TS42E05-00	
MODEL: TS-42E05		SCALE: 2:1	CHK'D	DWN. ZHOUYU 2002-8-7
ALL MATERIALS MUST BE COMPLIANT TO ROHS			FANGYING	2002-8-7
			KANGXINAN	2002-8-7